



**GTI-DWT-1000-1.9**  
1000 GALLON HDPE DOUBLE WALL  
VERTICAL TANK 1.9SG

- Tank has a Diameter of 64” and Height of 89”
- Capacity: 1000 Gallons.
- Rated for storage of liquids up to 1.9 specific gravity (15.8 pounds per gallon).
- Molded from FDA approved High Density Polyethylene (HDPE).
- Complies with FDA standards 21 CFR 177.1520 (1) 3.1 and 3.2.
- HDPE has a maximum continuous use temperature of 130 F.
- HDPE tank is approved for potable water.
- Meets ASTM D 1998-06 Wall Thickness Standard Specification for Polyethylene Upright Storage Tanks.
- Translucent White in color.
- Type of tank: DOUBLE WALL.
- This is an above ground tank. It is rated for atmospheric pressure only.
- Weight: 615 pounds.

**[www.GlobalTreat.com](http://www.GlobalTreat.com)**

[info@globaltreat.com](mailto:info@globaltreat.com)

281-370-3425



# GTI-DWT-1000-1.9

1000 GALLON HDPE DOUBLE WALL  
VERTICAL TANK 1.9SG

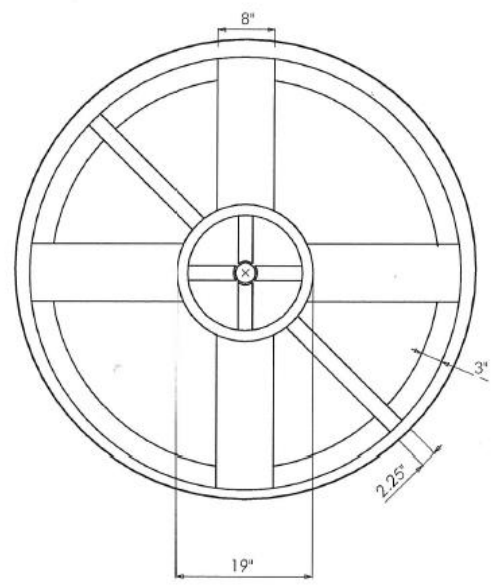
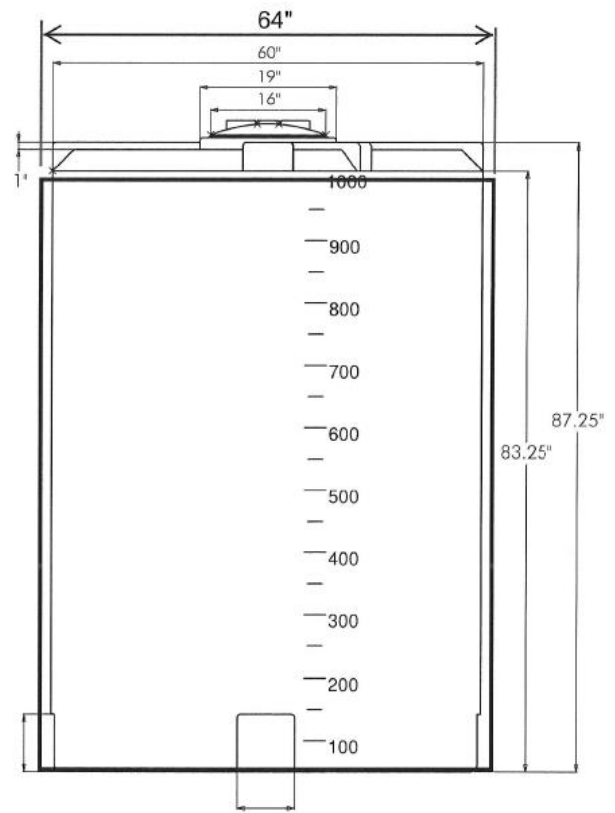

[www.GlobalTreat.com](http://www.GlobalTreat.com)  
info@globaltreat.com  
281-370-3425