



GTI-DWT-120-1.9
120 GALLON HDPE DOUBLE WALL
VERTICAL TANK 1.9SG

- Diameter of 32" and Height of 54".
- Tank Capacity: 120 Gallons.
- Rated for storage of liquids up to 1.9 specific gravity (15.8 pounds per gallon).
- Molded from FDA approved High Density Polyethylene (HDPE).
- Complies with FDA standards 21 CFR 177.1520 (1) 3.1 and 3.2.
- HDPE has a maximum continuous use temperature of 130 F.
- HDPE tank is approved for potable water.
- Translucent White in color.
- Type of tank: DOUBLE WALL.
- This is an above ground tank. It is rated for atmospheric pressure only.
- Weight: 130 pounds.



GTI-DWT-120-1.9

120 GALLON HDPE DOUBLE WALL
VERTICAL TANK 1.9SG

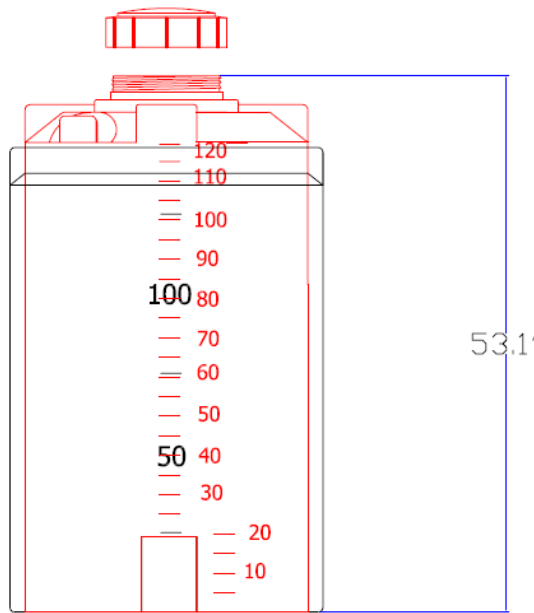

SIDE VIEW

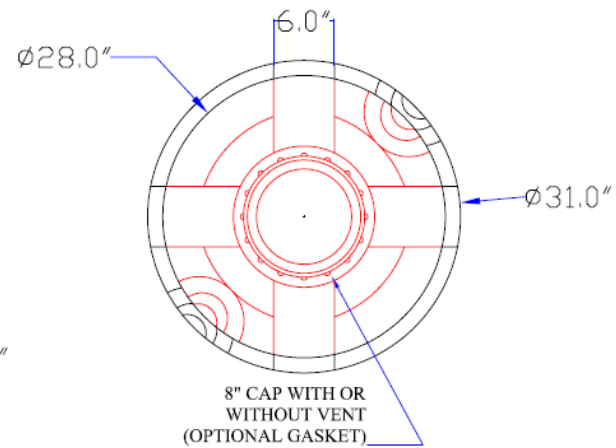

TOP VIEW