



GTI-DWT-3000-1.5

3000 GALLON HDPE DOUBLE WALL
VERTICAL TANK 1.5SG

- Tank has a Diameter of 102” and Height of 131”
- Tank Capacity: 3000 Gallons.
- Molded from FDA approved High Density Polyethylene (HDPE).
- Complies with FDA standards 21 CFR 177.1520 (1) 3.1 and 3.2.
- HDPE has a maximum continuous use temperature of 130 F.
- This HDPE tank is approved for potable water.
- Meets ASTM D 1998-06 Wall Thickness Standard Specification for Polyethylene Upright Storage Tanks.
- WHITE in color.
- Type of tank: DOUBLE WALL.
- This is an above ground tank. It is rated for atmospheric pressure only.
- Weight: 1290 pounds.



GTI-DWT-3000-1.5

3000 GALLON HDPE DOUBLE WALL
VERTICAL TANK 1.5SG

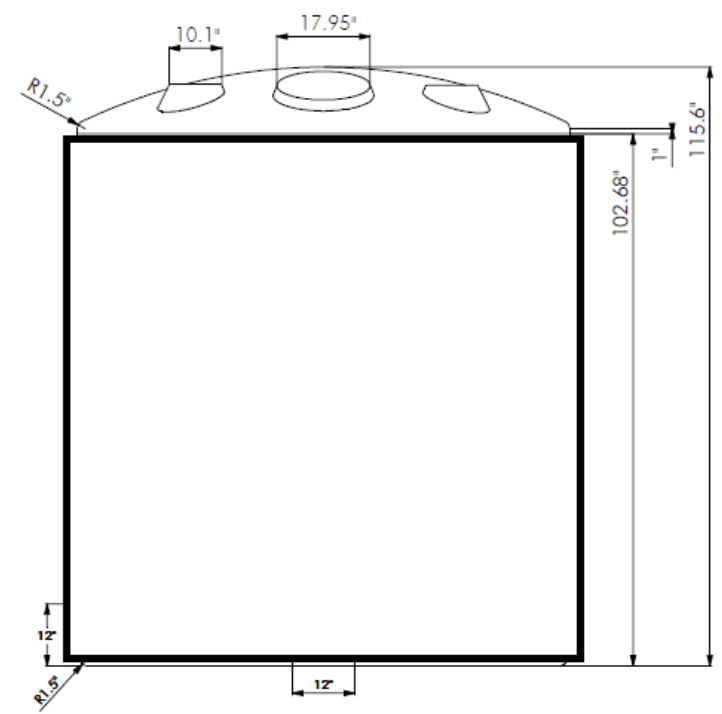
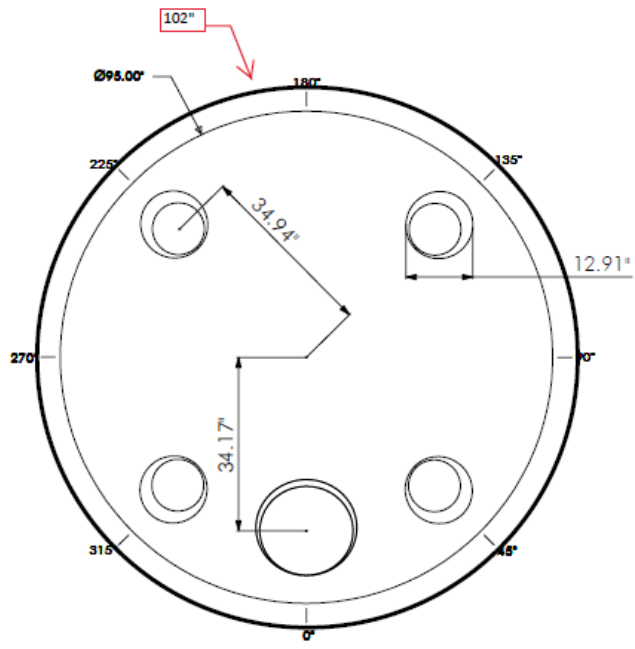

www.GlobalTreat.com
info@globaltreat.com
281-370-3425