

Fiberglass Shelter

Standard Drawing

Model # GTI-SH-7272

(6' x 6')

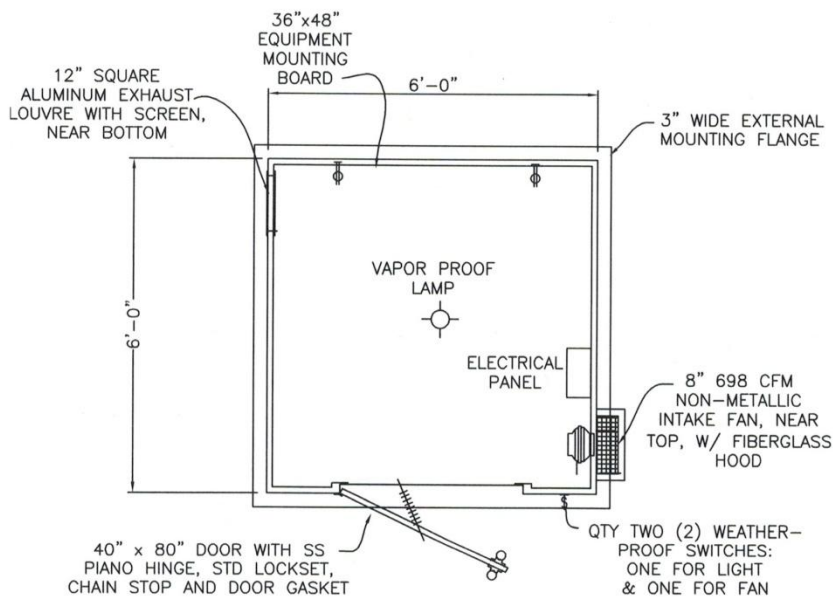

FLOOR PLAN

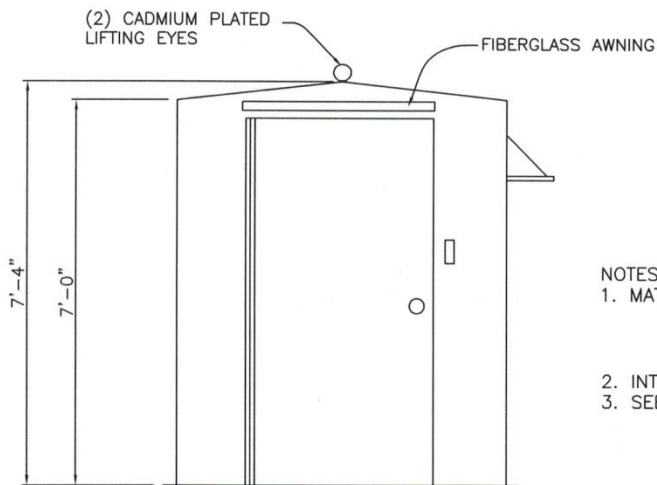

ELEVATION

NOTES:

1. MATERIALS OF CONSTRUCTION:
1/8" THK FIBERGLASS SKINS W/1" THK POLYISOCYANURATE FOAM (R=6.7) INSULATION CORE.
2. INTERIOR & EXTERIOR WHITE GEL COAT.
3. SEE CAD-PANEL FOR ELECTRICAL PANEL.